



For Earth, For Life
Kubota

U

KUBOTA ULTRA-COMPACT EXCAVATORS U10-5

The next generation of ultra-compact excavators with advanced performance and comfort.



*This information is sourced from overseas and may not necessarily apply locally. It is essential that you confirm specifications and other information with your local Kubota dealer.

**Ultra-compact dimensions, sup
minimal tail swing...everything**



erb operator protection, you need to get the job done.

There's a lot to like about Kubota's new ultra-compact excavators. They're so compact you can easily work safely in tight spots. They also have an improved control layout and upgraded comfort features to keep you working efficiently and comfortably. Best of all, you can depend on these Kubota ultra-compact excavators to get the job done with speed and efficiency.

SIDE LEVER LAYOUT

The control levers of the U10-5 are positioned to the sides of the seat for a better, more relaxed operator working posture and excellent forward visibility.



KUBOTA ULTRA-COMPACT EXCAVATORS

U10-5

Engine gross horsepower (SAE J 1995): 10.3 HP (7.7 kW)

Bucket breakout force: 550 kg

Operating weight*: 1200 kg

* Including operator's weight @ 75 kg

PERFORMANCE /

From an adjustable track gauge and two-speed travel pedal to Engine Safety Start and a new boom-mounted LED work light, this ultra-compact excavator is designed for maximum performance and safety.



Adjustable Track Gauge

With easy, single-lever operation, the U10-5's hydraulically adjustable track gauge reduces in seconds—down to 750 mm—to enable navigation in narrow spaces. Conversely, you can widen the track gauge all the way out to 990 mm. With the simple removal of one pin, its quick-fold blade adjusts in size instantly. When adjusted down, these ultra-compact excavators can easily fit through most doorways, permitting access inside of buildings.

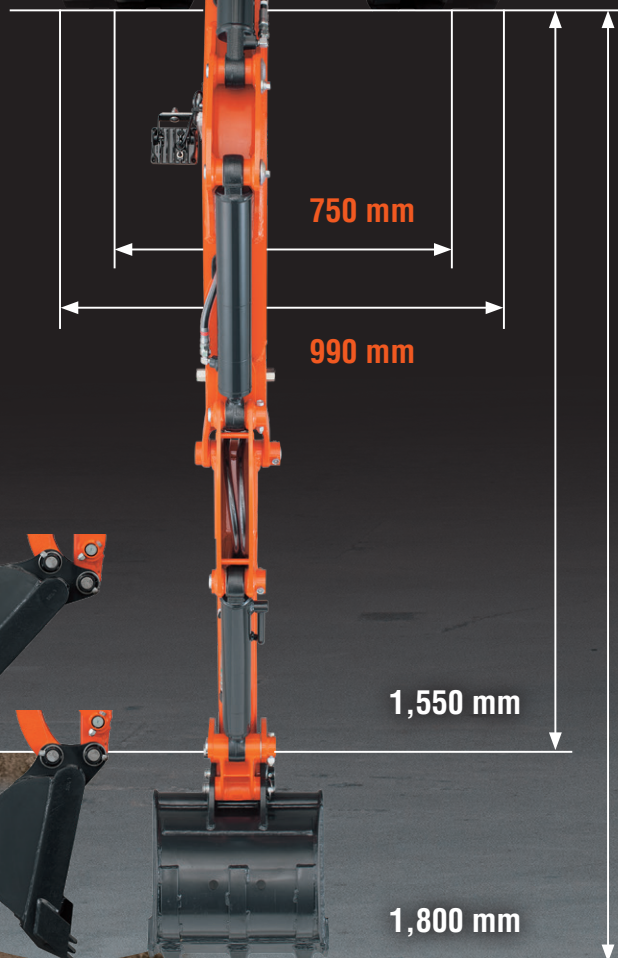

Digging Range

The Kubota ultra-compact excavators excel at digging, with surprisingly wide working and digging ranges for such compact excavators.

Hydraulic Pilot Control System

The U10-5's hydraulic pilot control system means smoother operation, improved feel, and an increase in digging productivity.

Boom Cylinder Protection Design

Notice the clean, hose-free look of the U10-5's boom. That is because all of their hydraulic hoses are uniquely hidden and protected inside the boom. In addition, the boom cylinder is well protected due to its location at the top of the boom.

SAFETY

Engine Safety Start

The Engine Safety Start system prevents the engine from starting when the levers are lowered. This system prevents unexpected excavator and attachment movement when starting the machine.

Two-speed Travel Pedal

This pedal lets you easily switch between high and low speeds, so you can work at your own pace. Simply depress the pedal for high-speed travel, or release it for low speed. This feature makes traveling between on-site locations more efficient.



Unload Lever

The unload lever enhances work safety by preventing unintended operation of the front attachment, dozer, AUX, swiveling, or traveling when the machine is in locked position.

New LED Boom Work Light

Bright LED boom work light provides plenty of illumination for nighttime tasks.



TPSS

TPSS is standard equipment, allowing the operator to select the most familiar operating control pattern, either ISO or SAE.

Foldable ROPS

For additional versatility, a foldable rollover protective structure is fitted as standard. Folding the ROPS down lets you easily transport the ultra-compact excavator on trucks, and travel under doorways to work indoors.



SERVICE

Thanks to a full-opening engine cover that provides easy access to the engine and conveniently located and protected hydraulic service port pipes, maintenance is simple.

Full Opening Engine Cover

The engine covers tilt-up operation exposes most of the engine—providing easier access to components.



Two-piece Hose Design

When an on-site replacement of a dozer cylinder supply hose is necessary, its two-piece design simplifies the job.



Protected Hydraulic Service Port Pipes

With the U10-5, you'll never need to replace the hydraulic service port pipes again. To reduce the risk of damaging the hydraulic piping, the service port pipes are hidden inside the boom, and its service ports are conveniently located at the end of the boom.

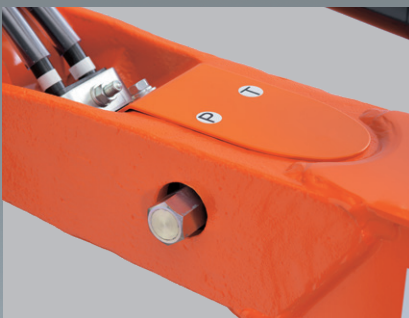

U10-5 OPTIONS

Standard Equipment

Engine

- Kubota original engine

Undercarriage

- 180mm rubber track
- Variable track
- 2-speed travel
- Double flange track rollers (piece number on each track: 3 pcs)

Hydraulic system

- Hydraulic pressure checking ports
- One-way auxiliary circuit (AUX1) via foot pedal control
- Hydraulic pilot control levers with wrist rests
- TPSS

Safety system

- Engine start safety system
- Hydraulic lock system
- Travel alarm

Working equipment

- 1 LED working light on the boom

Canopy

- ROPS (Roll-over Protective Structure, ISO3471)

Optional Equipment

Others

- AUX1 2-way circuit kit
- Beacon lights

Working Range

Model		U10-5		
A	Max. digging height	mm	3050	
B	Max. dumping height	mm	2210	
C	Max. digging depth	mm	1800	
D	Max. vertical digging depth	mm	1550	
E	Max. digging radius, at ground level	mm	3330	
F	Max. digging radius	mm	3380	
G	Min. turning radius	w/o swing	mm	1260
		with swing	mm	1075
H	Min. tail turning radius	mm	510	

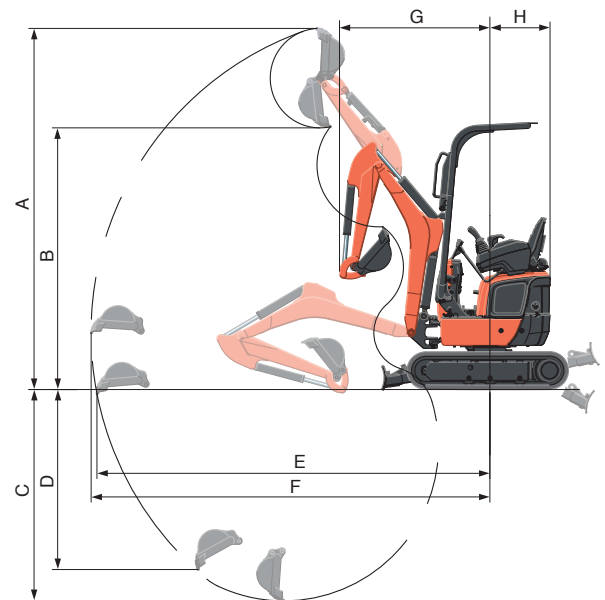

Lifting Capacity

LIFT POINT HEIGHT (m)	LIFTING CAPACITY OVER-FRONT BLADE DOWN unit=ton			LIFTING CAPACITY OVER-SIDE unit=ton			
	LIFT POINT RADIUS (m)			LIFT POINT RADIUS (m)			
	1.5	2	2.5	1.5	2	2.5	
1.5	—	0.19	0.19	—	0.19	0.13	
1	0.31	0.24	0.19	0.28	0.18	0.12	
0.5	0.45	0.27	0.20	0.26	0.17	0.12	
GL	0	0.42	0.27	0.19	0.24	0.16	0.12

Machine with ROPS canopy and rubber crawler, without bucket

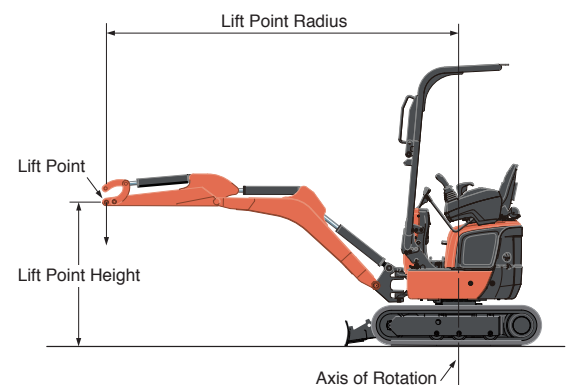

Specifications

Model		U10-5		
Type of ROPS / FOPS		Canopy		
Type of tracks		Rubber		
Engine	Model	D722-E4-BH-5US		
	Output (SAE J1995 gross)	HP (kW) @ rpm	10.3 (7.7) @ 2050	
	Output (SAE J1349 net)	HP (kW) @ rpm	10.1 (7.5) @ 2050	
	Displacement	cc	719	
Dimensions	Overall length	mm	2980	
	Overall height	mm	2260	
	Overall width	Standard	mm	990
		Narrow	mm	750
	Track gauge	Standard	mm	990
		Narrow	mm	750
Min. ground clearance	mm	140		
Hydraulic system	Pump capacity	ℓ/min	10.5 × 2 / 3.1 × 1	
	Auxiliary hydraulic flow	ℓ/min	21	
	Max. breakout force	Bucket / Arm	kgf	1060 / 550.6
Drive system	Travel speed	Low / High	km/h	2.0 / 4.0
	Tumbler distance	mm	1010	
	Crawler length	mm	1340	
	Shoe width	mm	180	
	Ground contact pressure	kgf/cm ²	0.30	
Swing system	Unit swing speed	rpm	8.3	
	Boom swing angle	Left / Right	degree	55 / 55
Blade	Dimensions	Width Std / Narrow	mm	990 / 750
		Height	mm	200
	Max. lift above ground	mm	215	
	Max. drop below ground	mm	190	
Hydraulic oil (Reservoir / System)	ℓ	12.6 / 17.1		
Fuel reservoir	ℓ	12		
Operating weight (Including operator's weight @ 75 kg)	kgf	1200		

The company reserves the right to change the above specifications without notice. This brochure is for descriptive purposes only. Please contact your local Kubota dealer for warranty information. For your safety, Kubota strongly recommends the use of a Rollover Protective Structure (ROPS) and seat belt for almost all applications.

Dimensions

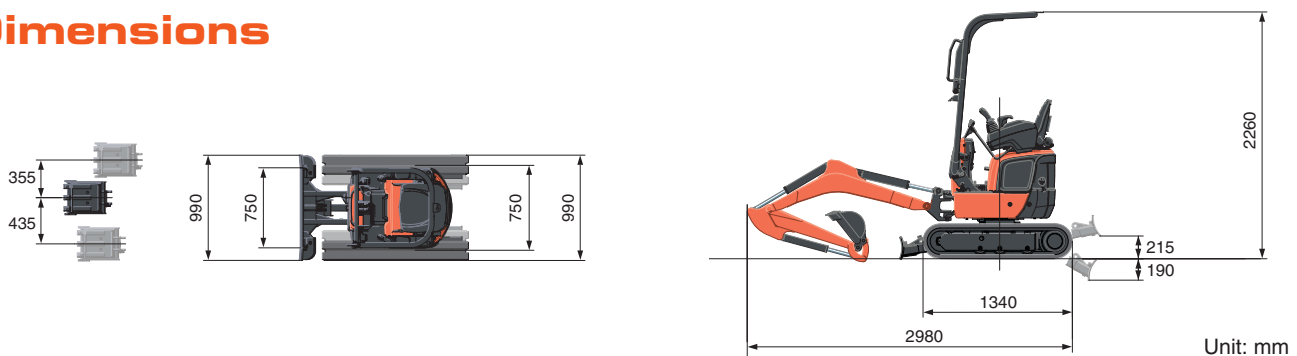

©2022 Kubota Corporation

Kubota Australia Pty Ltd

25-29 Permas Way, Truganina VIC, 3029 Australia
 Freecall: 1800-334-653
 Email: sales@kubota.com.au

Web Site: <http://www.kubota.com.au>

Kubota New Zealand Limited

433 Rangitikei Street, Cloverlea, Palmerston North, 4412
 New Zealand
 Freecall: 0800-582-682
 Email: sales@kubota.com.au

Web Site: <http://www.kubota.co.nz>

**Kubota
Genuine Parts**
 for maximum
 performance,
 durability and
 safety